

# Applications of Memory Networks

## --NLP bimonthly report

Yang Feng  
2016-11-02

# Applications

- Parsing
- Poetry generation
- Sequence-to-sequence generation, e.g. QA, machine translation

# Basics Preparation

- Memory network
  - Ran the open-source code and get comparative results with the paper.
  - Read the code (Torch) [\[code\]](#)

# Parsing

## Framework:

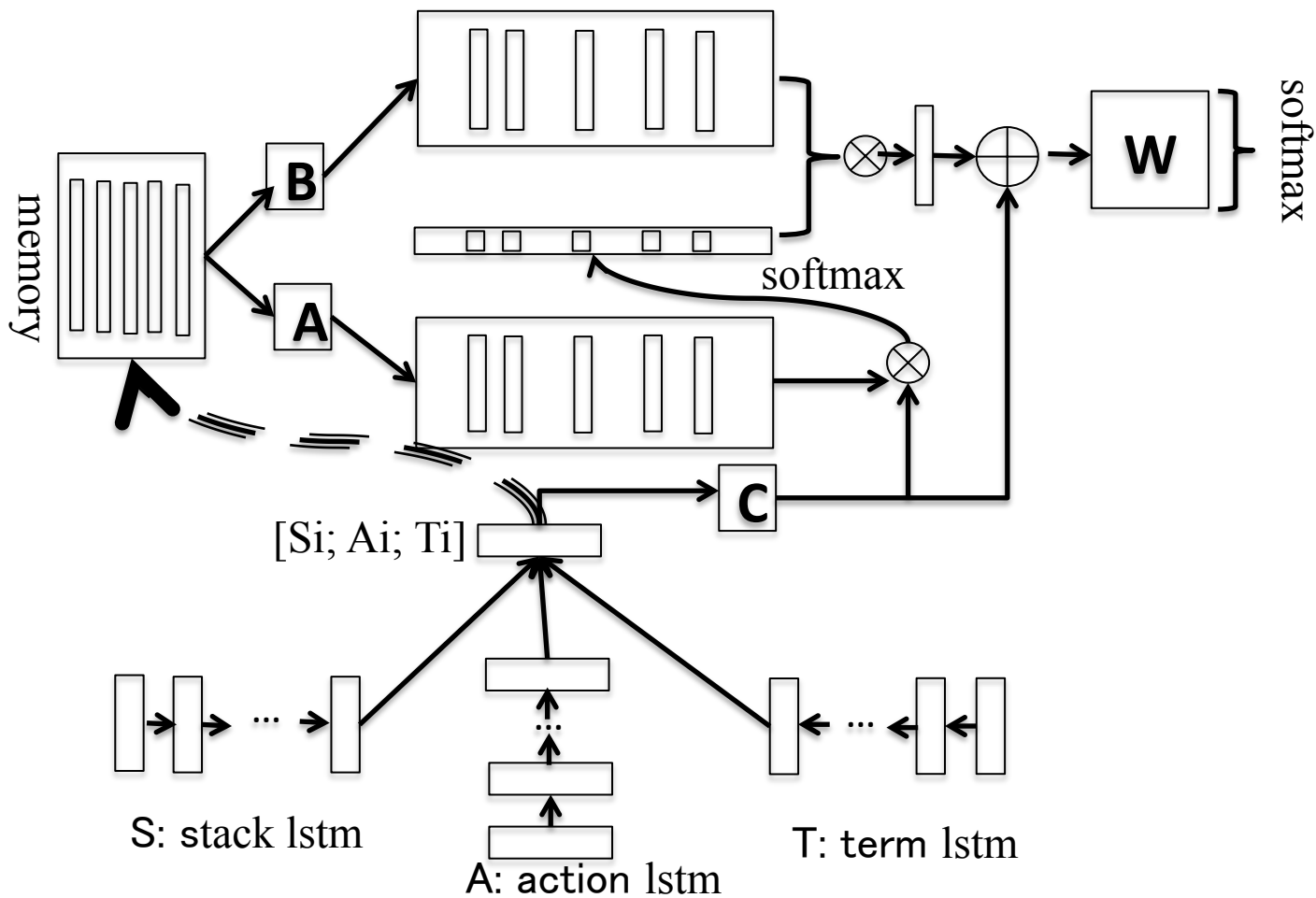

# Parsing: Progress

- Basics Preparation
  - Ran the open-source code and get slightly better results than the paper.
  - Read rnng code (C++). [\[code\]](#)

# Parsing: Progress

- Initial Model

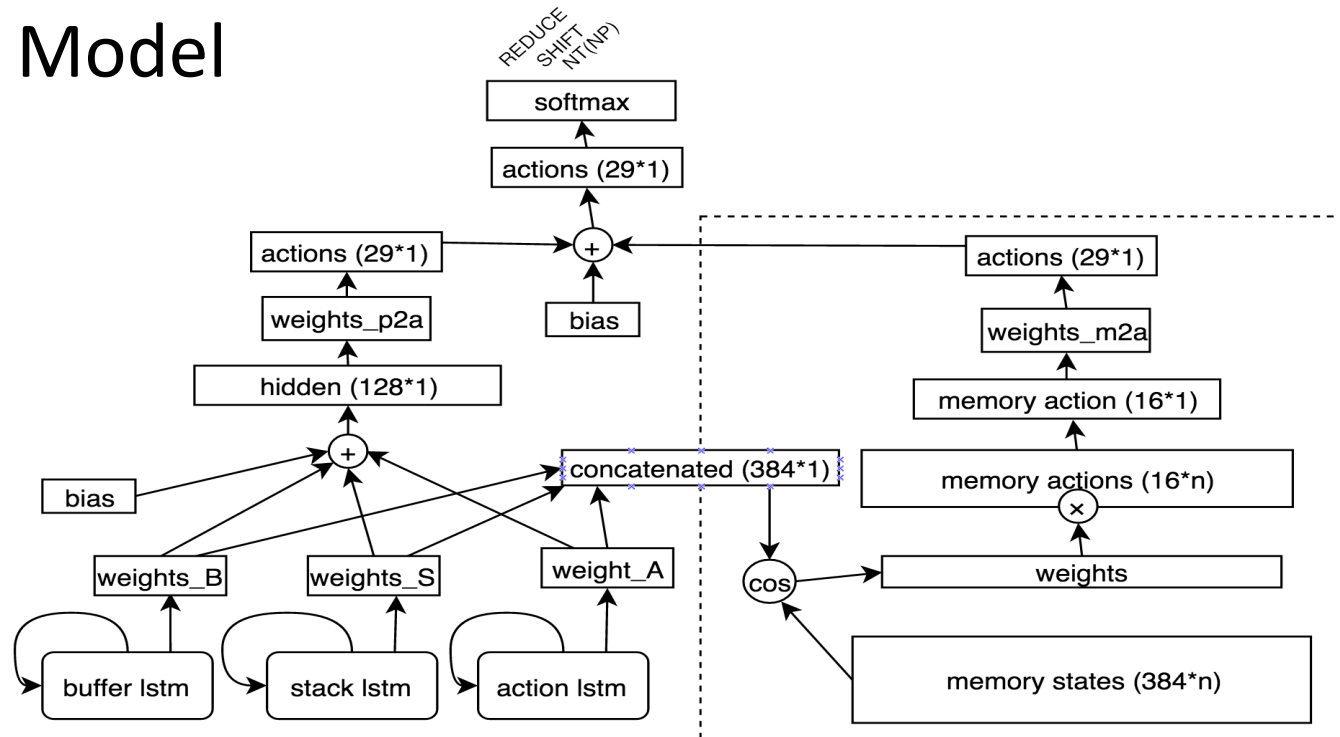

- Progress

- Doesn't work so far
- Under optimization

# Parsing: Progress

- Cascade Model
  - Train lstm
  - Train memory network with lstm parameters fixed
- Progress
  - Under training

# Parsing: Progress

- Joint Model
  - Coding [90%]



# Poetry Generation

- Fixed bugs of basic model and got competitive result with Qixin's system [\[result\]](#)
- Added memory networks to the basic model and got the initial result. [\[mnresult\]](#)

# Sequence-to-sequence generation

- Basics preparation
  - Ran open-source code and met with some problems (cost keep ascent)
  - Read open-source code (Theano) [under-going]
  - Paraphrase data preparation.

# Reading and Document

- Reading group:
  - 6 papers [\[reading group\]](#)
- Document:
  - A report of music generation [\[report\]](#)
  - Rnng user guide and manual [\[user guide\]](#)
  - Cnn platform manual (keep updating) [\[manual\]](#)

# Next Plan (2016.11-12)

- Parsing
  - Get the results of joint model
  - Optimization
- Poetry generation
  - Fix bugs
  - optimization
- Sequence-to-sequence generation
  - Manage to get good result as the paper
  - Add memory network
  - Get the result of paraphrase